



Ross High Speed Dispenser

Traditional ROSS quality and heavy duty construction.

Durable, Dependable, Simple and Affordable.

Ross has been the leader in the mixing industry for over 165 years. The ROSS High Speed Dispenser is built with all of the features and versatility required to produce a variety of products. This old age design has been refined and updated for longer life, improved performance and reduced costs.

The standard design includes features such as Explosion Proof Inverter Duty Motors, heavy duty v-belt drives and bearings safety switches for both

height limitation and mix can position, adjustable can lock system for use with different size mix vessels, air/oil hydraulic system including manual controls, Stainless Steel shaft guards and Stainless Steel shaft guards.

Available in all standard sizes and special design configurations. Custom designs to meet all of your dispersing and mixing needs.



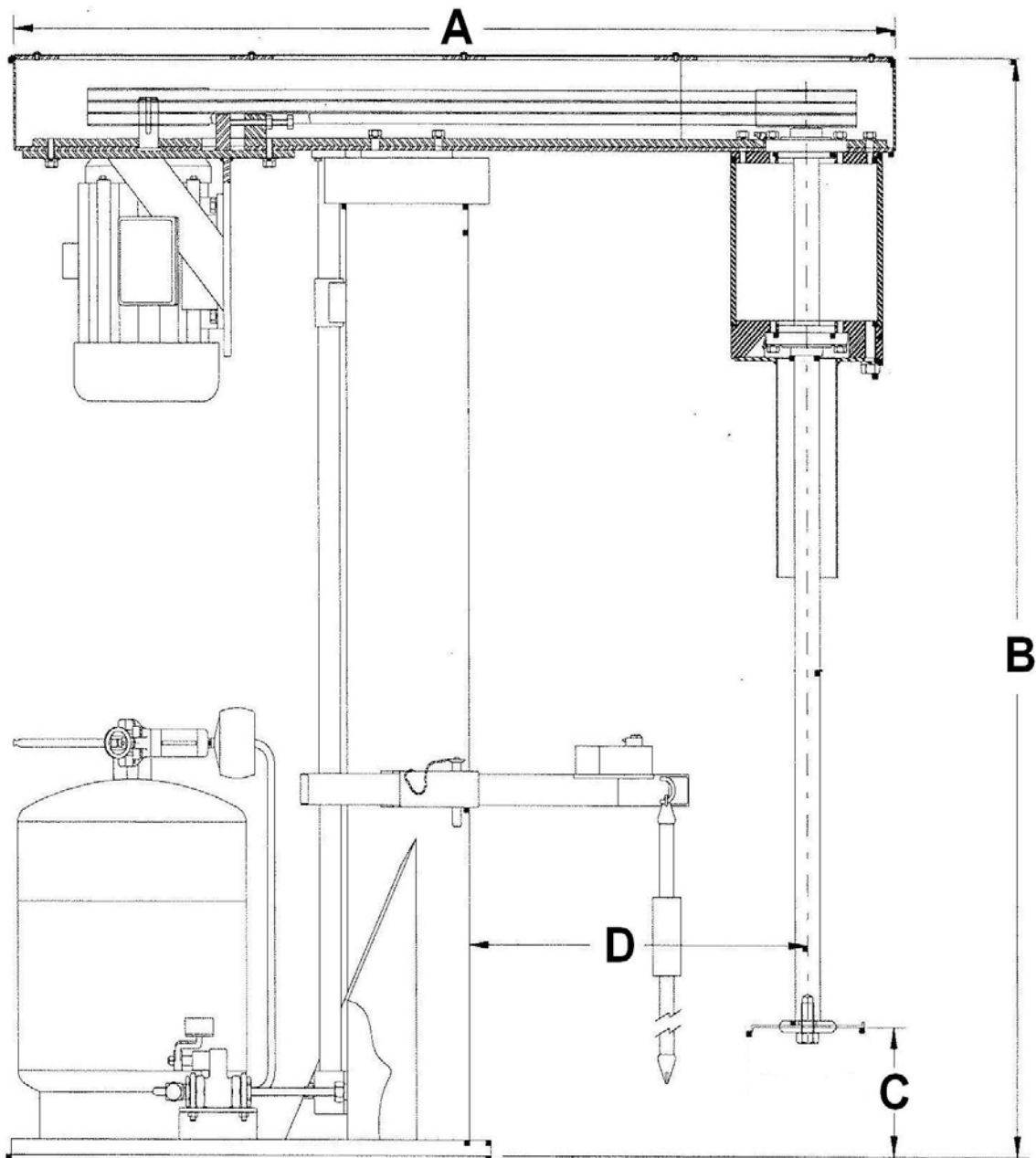

Applications

- Pigment Dispersions
- Automotive Coatings
- Dye Stuffs
- Electronic Inks
- High Performance Ceramics
- Plastisols
- Carbon Dispersions
- Graphite Composite
- Magnetic Dispersions
- Paints
- Glass Coatings

The ultimate test – in the Ross Test & Development Center or in your plant.

Call Ross to arrange a demonstration of our HSD and other models. The Ross Test & Development Center is staffed with the most experienced engineers in the business and is fully equipped for quantitative analysis of your results.

Call or email Ross today.
1-800-243-ROSS
sales@mixers.com

Call now to speak to an application engineer. Learn more about the Ross HSD and all of the other Ross products.

Model	HP	A Overall Length (in)	Overall Width (in)	B Overall Lowered Height (in)	C Lowered Blade Clearance (in)	Lift Rise (in)	D Shaft to Lift Distance (in)	Standard Blade Diameter (in)	Shaft RPM
HSD-5	5	63	24	70	8	48	24	6	3200
HSD-7.5	7.5	63	24	70	8	48	24	8	2400
HSD-10	10	63	24	70	8	48	24	10	1900
HSD-15	15	63	24	70	8	48	24	12	1600
HSD-20	20	63	24	72	8	48	24	14	1400
HSD-25	25	82	28	72	6	50	30	16	1200
HSD-30	30	82	28	72	6	50	30	16	1200
HSD-50	50	84	28	106	14	66	34	18	1100

*Specification sheets for laboratory models available separately.

**Larger horsepower and custom designs are also available.



CHARLES ROSS & SON COMPANY
 P.O. Box 12308
 710 Old Willets Path
 Hauppauge, NY 11788
 Tel: 631-234-0500
 Fax: 631-234-0691
 1-800-243-ROSS
 Website: www.mixers.com
 Email: sales@mixers.com